

A-T ARMATUREN-TECHNIK GMBH

Absperr-Armaturen, Regelventile, Turbinen-Umleitsysteme für Kraftwerkstechnik, Öl und Gas Pipelines

Isolating, control valves and turbine bypass systems for the electric power industry, oil and gas pipelines



VALVES

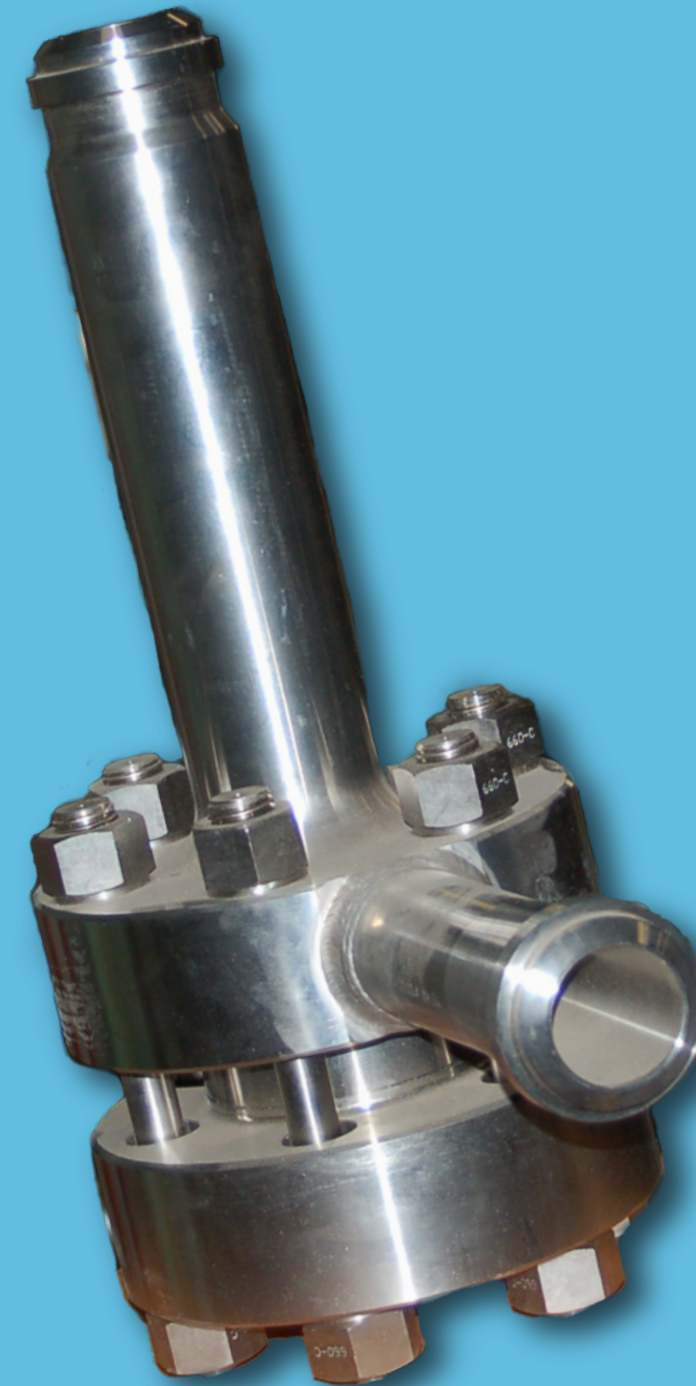

A-T ARMATUREN-TECHNIK GMBH

Duisburger Strasse 375

T-Building

46049 Oberhausen (Germany)

phone: +49.208.833-1700

fax: +49.208.833-1755

web: www.at-armaturen.com

email: sales@at-armaturen.com

Throttling Section DS

A-T ARMATUREN-TECHNIK GMBH

Throttling Section DS

VALVES

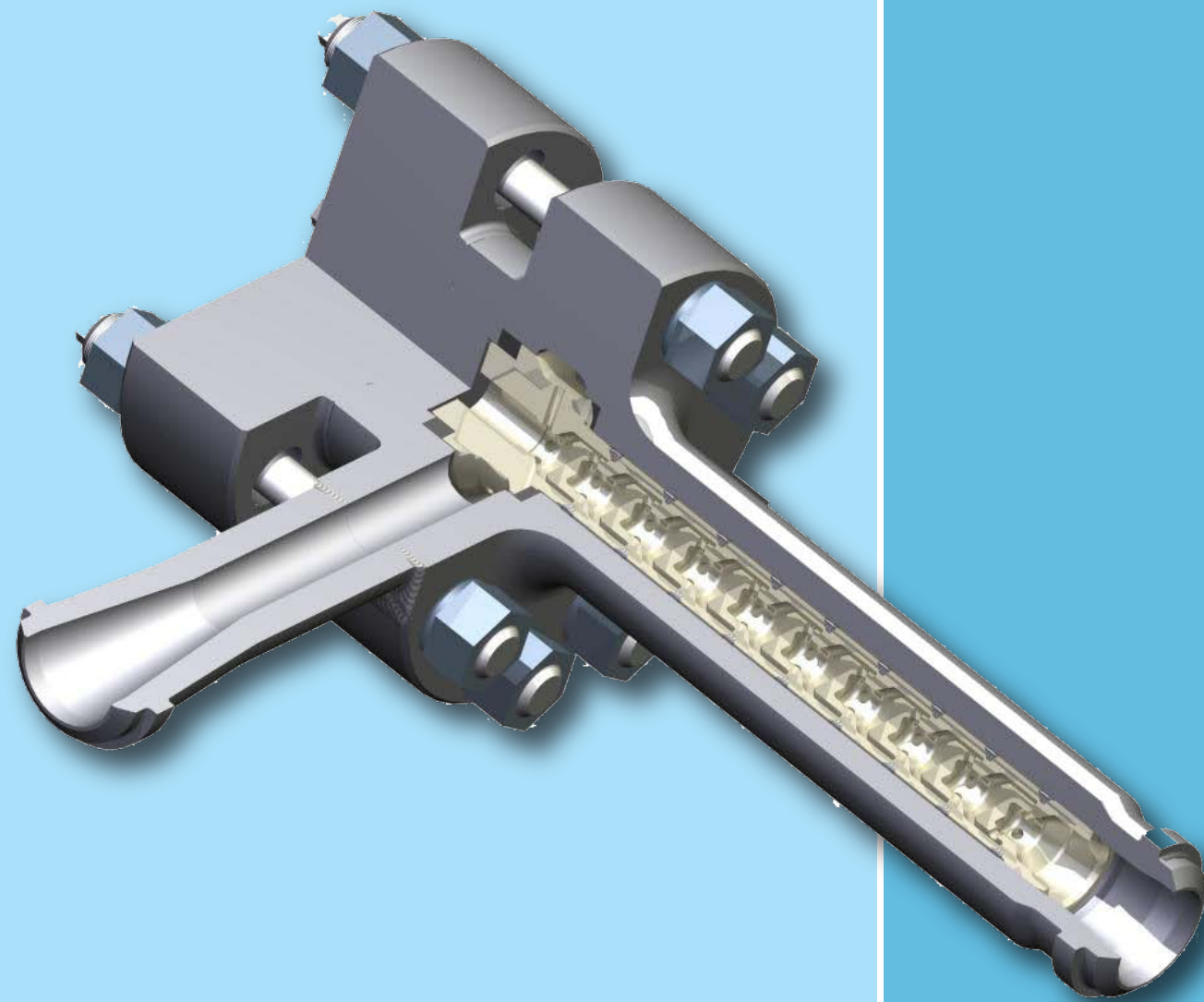

Throttling section
with weld sealing

Advantage

- Reliable throttling unit for all known pressure differential
- Rugged, simple construction, few components
- Operationally reliable, robust, wear resistant
- Long service life
- Maintenance-free except for occasional tightening of the cover bolts of the angled and Z types
- Body and internal parts of forged steel
- Only 5 sizes cover all known operating conditions, can be installed in any Position
- Special designs on request

Application

Throttling sections are used to reduce the supply pressures to any desired lowerdownstream pressure in places where high pressure differentials exist. Throttling sections can also maintain constant supply pressures at constant flow rates. Throttling sections can be used for water and other liquids a certain amount of erosion can be expected when used with corrosive liquids.

Design and mode of Operation

- Throttling sections are made as straight through types, Z types and angled types, The Z type and angled type are fitted with loose, easily replaced.
- The bodies can be designed with welded ends, socket welds or flanges.
- There are 5 sizes to choose iron depending on the low rate.
- Pressure reduction follows the throttling principle by which the medium passes through successive throttling stages to the outlet.
- In each throttling stage, the medium flows from the outside to the inside through radiallyopposed holes. This causes the partial flows to rebound concentrically.
- Before every start-up the nuts of the sealing devices of the angled and Z types must be checked and tightened if necessary. This Operation must be repeated at specific intervals during operation. When assembling throttling sections, care must be taken to ensure that the flow takes place in the direction of the arrow. The correct heat treatment and welding regulations must be observed by welding.