



Swing Check Valve type RK

200 MW / 300 MW / 600 MW / 750 MW / 1000 MW

- High-pressure valve
- DN 80 - 1500 / NPS 3" - 60"
- PN 20 - 50 / ANSI Class 150 - 300
- High steam temp. acceptable
- High water temp. acceptable

Size: DN 80 - 1500 / NPS 3" - 60"
other sizes on request

Rating: PN 20 - 50 / Class 150 - 300
other ratings on request

Design: forged steel-welding
construction,
straight pattern

Connections: welding ends, flanges

Actuators: according to specifications

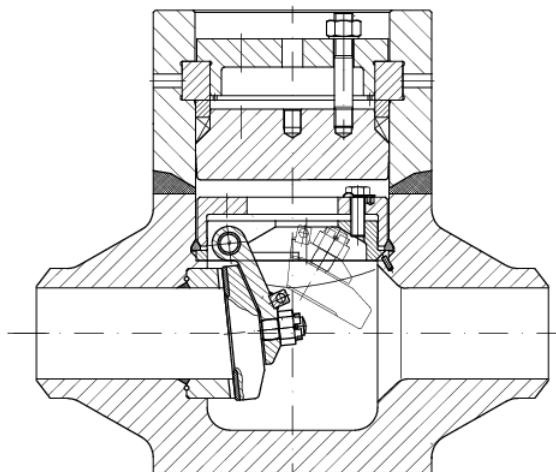

All materials according to DIN or ANSI / ASTM.
For the main parts of our valves we use standard material as listed below or according to our customer specifications.

| Material acc. to DIN | Description acc. to DIN | Material ASTM/AISI/ASME |
|----------------------|-------------------------|-------------------------|
| 1.0460 | C22.8 | ASTM A105 |
| 1.4541 | X6CrNiTi18-10 | SUS 321 |
| 1.4571 | X6CrNiMoTi17-12-2 | SUS 316Ti |
| 1.4903 | X10CrMoVNb9-1 | ASTM A182 F91 |
| 1.4922 | X20CrMoV12-1 | |
| 1.5415 | 16Mo3 | ASTM A182 F1 |
| 1.7335 | 13CrMo4-5 | ASTM A182 F12 |
| 1.7380 | 10CrMo9-10 | ASTM A182 F22 |