

Wedge Gate Valve type K

200 MW / 300 MW / 600 MW / 750 MW / 1000 MW

- High-pressure valve
- DN 80 – 1500 / NPS 3” – 60”
- PN 20 – 630 / ANSI Class 150 - 4500
- Wedge plug
- High steam temp. acceptable
- High water temp. acceptable
- Bypass on request

Nominal Size: DN 80 - 1500 / NPS 3” - 60”
other sizes on request

Rating: PN 20 - 640 / Class 150 - 4500
other ratings on request

Control characteristic: on - off

Design: forged steel-welding
construction,
straight pattern

Connections: welding ends, flanges

Actuators: hydraulic actuator,
electric actuator,
manual operated
according to specifications

All materials according to DIN or ANSI / ASTM.
For the main parts of our valves we use standard
material as listed below or according to our
customer specifications.

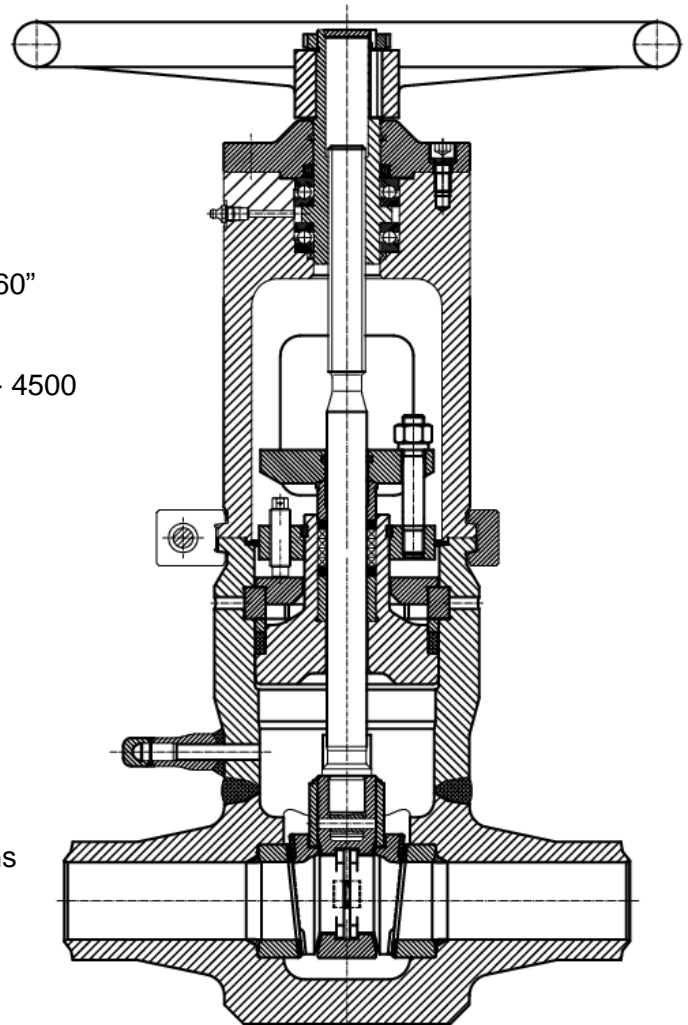

| Material acc. to DIN | Description acc. to DIN | Material ASTM/AISI/ASME |
|-------------------------|----------------------------|----------------------------|
| 1.0460 | C22.8 | ASTM A105 |
| 1.4541 | X6CrNiTi18-10 | SUS 321 |
| 1.4571 | X6CrNiMoTi17-12-2 | SUS 316Ti |
| 1.4903 | X10CrMoVNb9-1 | ASTM A182 F91 |
| 1.4922 | X20CrMoV12-1 | - |
| 1.5415 | 16Mo3 | ASTM A182 F1 |
| 1.7335 | 13CrMo4-5 | ASTM A182 F12 |
| 1.7380 | 10CrMo9-10 | ASTM A182 F22 |